

Preventing Overloading Incidents on Smart Grids: A Multiobjective Combinatorial Optimization Approach

Nikolaos Antoniadis¹

Maxime Cordy¹

Angelo Sifaleras²

Yves Le Traon¹

¹UNIVERSITY OF LUXEMBOURG

Interdisciplinary Centre of Security, Reliability and Trust (SnT)
Luxembourg, Luxembourg

²UNIVERSITY OF MACEDONIA

Department of Applied Informatics
Thessaloniki, Greece



- 1 Introduction
 - Motivation
 - Computational paradigm
- 2 Mathematical model
 - Notation
 - Formulation
- 3 Evaluation
 - Dataset and experimental setup
 - Results
- 4 Conclusions and future work
 - Conclusions
 - Future work

- 1 Introduction
 - Motivation
 - Computational paradigm
- 2 Mathematical model
 - Notation
 - Formulation
- 3 Evaluation
 - Dataset and experimental setup
 - Results
- 4 Conclusions and future work
 - Conclusions
 - Future work

Introduction

- The low-voltage distribution grid is organized in a *multigraph*
- Its *vertices* are the **substations** and **cabinets**
- its *edges* are the power lines (**cables**) of the grid
- Every cable starts from a **fuse** in a cabinet and ends in an other's cabinet fuse
- Between the cable and each user installation a **smart meter** is installed

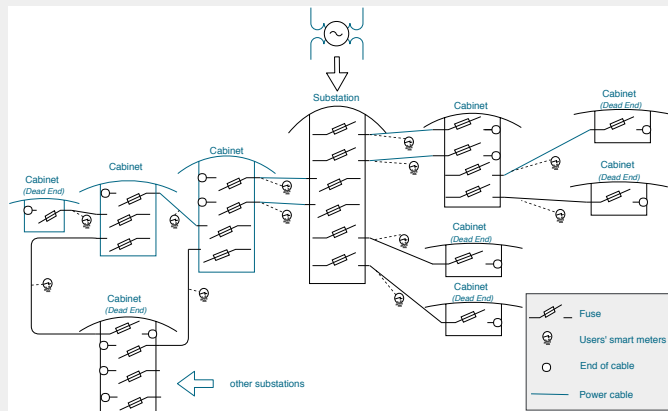

How to determine the **optimal sequence of actions**
to reconfigure a smart grid system?

- Limit the consumption and/or the production of the smart grid's users
- Change the state of the fuses (*controlling the reachability of the cables*)

How to determine the **optimal sequence of actions**
to reconfigure a smart grid system?

- Limit the consumption and/or the production of the smart grid's users
- Change the state of the fuses (*controlling the reachability of the cables*)

First example: Overloading cable

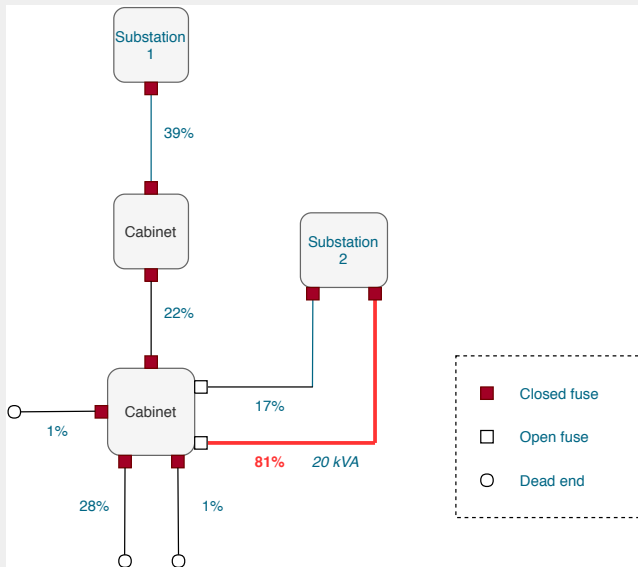

First example: Solution

Limiting power to over-consuming user

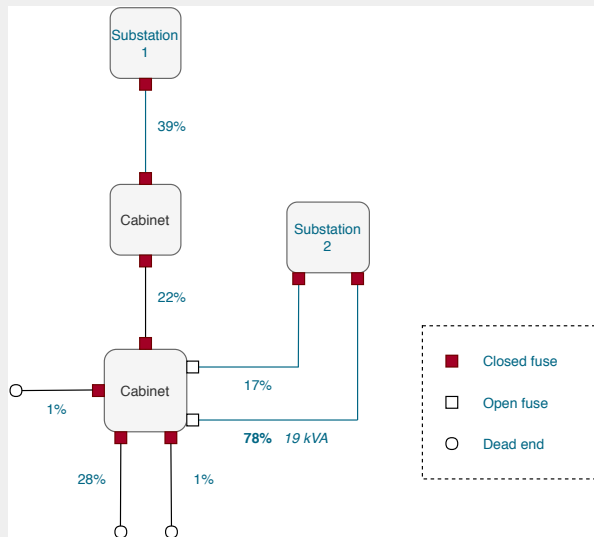

Second example: Overloading cable

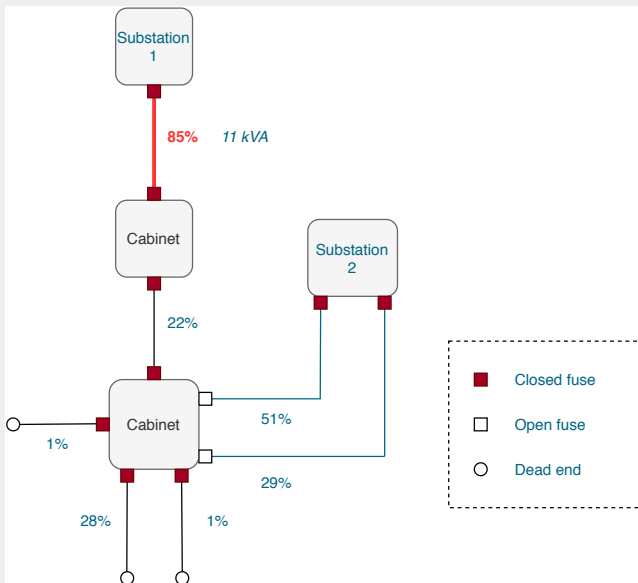

Second example: Solution

Change grid's topology when user regulation is not possible

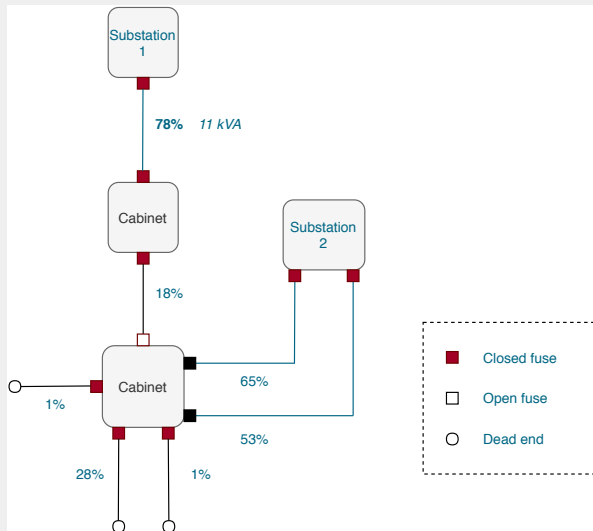

- 1 Introduction
 - Motivation
 - Computational paradigm
- 2 Mathematical model
 - Notation
 - Formulation
- 3 Evaluation
 - Dataset and experimental setup
 - Results
- 4 Conclusions and future work
 - Conclusions
 - Future work

Nomenclature (1/2)

n	number of cables, $n \in \mathbb{N}^*$
r_i	reachability cable state; 1 if cable i is powered and 0 otherwise
m	number of users, $m \in \mathbb{N}^*$
uc_{ki}	user cable indicator; 1 if user k is connected with cable i , 0 otherwise
o	number of cabinets (including substations), $o \in \mathbb{N}^*$
$dfcab_b$	cabinet visit indicator; 1 if $\sum_{f=1}^{2n} cc_{bf} x_f - x_f^0 \geq 1$, 0 otherwise
x_f	fuse state; 1 if fuse f is closed, and 0 otherwise; if $f = 2i$, x_f denotes the current state of the <i>start</i> fuse of cable i , else if $f = 2i + 1$, x_f denotes the current state of the <i>end</i> fuse of cable i
x_f^0	initial fuse state
cc_{bf}	fuse cabinet indicator; 1 if fuse f belongs to the cabinet b , 0 otherwise

Nomenclature (2/2)

A_{jf}	coefficient matrix element; for equation j and fuse f , $A_{jf} \in \{-1, 0, 1\}$
wp_f	actual active energy vector energy element for fuse f ; $wp_f \in \mathbb{R}$
P_j	active load vector element; $P_j = P_l \cdot r_l$, if equation j is describing the current flow of cable l , and 0 otherwise, $P_j \in \mathbb{R}$
Pl_l	initial active energy for cable l , $Pl_l = \delta \sum_{k=1}^m uc_{kl} RaE_k$
δ	measurement frequency coefficient; e.g. $\frac{60}{15} = 4$, for 15 min interval
RaE_k	real active energy consumption for user k , $RaE_k = aE_k$, if $cur_k < I_{LC}$, (consumer) or $cur_k < I_{LP}$ (producer), and $RaE_k = RGeE_k$ otherwise
aE_k	active energy for user k , $aE_k = aEC_k - aEP_k$, $aE_k \in \mathbb{R}$
aEC_k	active energy consumption for user k , $aEC_k \in \mathbb{R}_+$
aEP_k	active energy production for user k , $aEP_k \in \mathbb{R}_+$
rE_k	reactive energy for user k , $rE_k = rEC_k - rEP_k$, $rE_k \in \mathbb{R}$
rEC_k	reactive energy consumption for user k , $rEC_k \in \mathbb{R}_+$
rEP_k	reactive energy production for user k , $rEP_k \in \mathbb{R}_+$
cur_k	amperage of user k , $cur_k = \frac{\sqrt{aE_k^2 + rE_k^2}}{\sqrt{3} \cdot 230}$
I_{LP}	maximum allowed amperage for producers, e.g. 60A
I_{LC}	maximum allowed amperage for consumers, e.g. 32A
$RGeE_k$	curtailed active energy for user k , $RGeE_k = \sqrt{ 230^2 \cdot 3 \cdot I_R^2 - rE_k^2 }$, $RGeE_k \in \mathbb{R}_+$
I_R	curtailed amperage for users, e.g. 20A
wq_f	actual reactive energy vector energy element for fuse f ; $wq_f \in \mathbb{R}$
Q_j	reactive load vector element; $Q_j = Q_l \cdot r_l$, if equation j is describing the current flow of cable l , and 0 otherwise, $Q_j \in \mathbb{R}$
Ql_l	initial reactive energy for cable l , $Ql_l = \delta \sum_{k=1}^m uc_{kl} rE_k$
l_i	actual current load percentage, at cable i ; $l_i = \max\left(\frac{100 \sqrt{wp_{2i}^2 + wq_{2i}^2}}{230c_i \sqrt{3}}, \frac{100 \sqrt{wp_{2i+1}^2 + wq_{2i+1}^2}}{230c_i \sqrt{3}}\right)$
\bar{l}	maximum allowed current load percentage for all cables, e.g. 80%
i	cable index, $i \in \{1, \dots, n\}$

Mixed Integer Quadratically Constrained Program (MIQCP) formulation

1st objective : **Maximize the serviced users of the grid**

$$\max \sum_{i=1}^n r_i \sum_{k=1}^m u_{Cki} \quad (1)$$

2nd objective : **Minimize the number of visiting cabinets**

$$\min \sum_{b=1}^o dfcab_b \quad (2)$$

3rd objective : **Minimize the number of fuses' changes**

$$\min \sum_{f=1}^{2n} |x_f - x_f^0| \quad (3)$$

Approximate active energy for the current topology

$$A \cdot wp = P \quad (4)$$

Approximate reactive energy for the current topology

$$A \cdot wq = Q \quad (5)$$

Cable amperage constraint

$$I_i < \hat{I}, \forall i \in \{1, \dots, n\} \quad (6)$$

- 1 Introduction
 - Motivation
 - Computational paradigm
- 2 Mathematical model
 - Notation
 - Formulation
- 3 Evaluation
 - Dataset and experimental setup
 - Results
- 4 Conclusions and future work
 - Conclusions
 - Future work

- Topology generator
- 10 instances x 10 grid topologies x 216 scenarios = 21600 instances
- Consumption and production energy data based on historical data from *Creos Luxembourg S.A.*
- *Soft curtailment* is applied if
 - a producer overpasses the threshold of 60A, i.e., 80% of 75A, or
 - a consumer overpasses the threshold of 32A, i.e., 80% of 40A
- If a producer or a consumer is curtailed, its active energy is limited to 20A

- **First research question:**
scalability of our approach wrt. increasingly-large grids
- **Second research question:**
how well curtailment policies allow avoiding user disconnections?

Findings - 1st Research Question

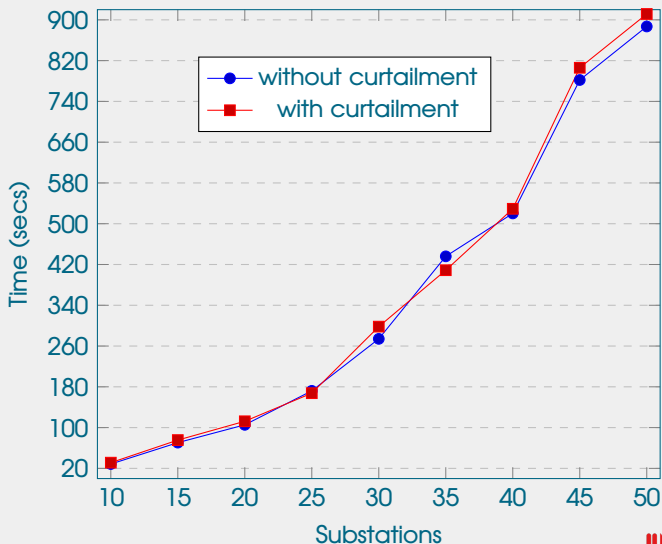

- When the size of the graph doubles, time is five times higher.

- 10 topologies with 5 substations
 - average time $6.363 \text{ sec} \pm 1.527 \text{ sec}$
- If overloaded consumers $\leq 10\%$ and overloaded producers $\leq 25\%$
 - **no disconnection is needed** (if we curtail all users)
 - 6.98% of cabinets should be visited
 - 3.47% of fuses should be changed
- With no curtailment, even when overload producers $\leq 10\%$
 - $5.43\% \pm 0.93\%$ of the users should be disconnected

- 1 Introduction
 - Motivation
 - Computational paradigm
- 2 Mathematical model
 - Notation
 - Formulation
- 3 Evaluation
 - Dataset and experimental setup
 - Results
- 4 Conclusions and future work
 - Conclusions
 - Future work

- Defined and formulated the overloading prevention problem in smart grids as a Multiobjective MIQCP.
- Suggested a solution method using a state-of-the-art exact solver.
- Can be included in the grid operator's decision-making process.
 - Prevent challenging overloading incidents in a smart grid
 - Minimizing the disconnections of the grid's users.

- Defined and formulated the overloading prevention problem in smart grids as a Multiobjective MIQCP.
- Suggested a solution method using a state-of-the-art exact solver.
- Can be included in the grid operator's decision-making process.
 - Prevent challenging overloading incidents in a smart grid
 - Minimizing the disconnections of the grid's users.

- Defined and formulated the overloading prevention problem in smart grids as a Multiobjective MIQCP.
- Suggested a solution method using a state-of-the-art exact solver.
- Can be included in the grid operator's decision-making process.
 - Prevent challenging overloading incidents in a smart grid
 - Minimizing the disconnections of the grid's users.

- Defined and formulated the overloading prevention problem in smart grids as a Multiobjective MIQCP.
- Suggested a solution method using a state-of-the-art exact solver.
- Can be included in the grid operator's decision-making process.
 - Prevent challenging overloading incidents in a smart grid
 - Minimizing the disconnections of the grid's users.

- It would be interesting to analyze the intermediate states to find the **optimal order** of fuses' change.
- Also, applying a **dynamic soft curtailment** policy would be a desired feature for the smart grid users.
- Another interesting addition should be the appliance of a **fairness policy** to avoid curtailing the same users repetitively over time.
- We should also consider the future states of the grid and their inherent stochasticity, as the recovery response solution should **guarantee stability over the next 24 hours**.
- We also plan to exploit **metaheuristic methods** to solve the overloading prevention problem, that may help us to address the additions mentioned above.

- It would be interesting to analyze the intermediate states to find the **optimal order** of fuses' change.
- Also, applying a **dynamic soft curtailment** policy would be a desired feature for the smart grid users.
- Another interesting addition should be the appliance of a **fairness policy** to avoid curtailing the same users repetitively over time.
- We should also consider the future states of the grid and their inherent stochasticity, as the recovery response solution should **guarantee stability over the next 24 hours**.
- We also plan to exploit **metaheuristic methods** to solve the overloading prevention problem, that may help us to address the additions mentioned above.

- It would be interesting to analyze the intermediate states to find the **optimal order** of fuses' change.
- Also, applying a **dynamic soft curtailment** policy would be a desired feature for the smart grid users.
- Another interesting addition should be the appliance of a **fairness policy** to avoid curtailing the same users repetitively over time.
- We should also consider the future states of the grid and their inherent stochasticity, as the recovery response solution should **guarantee stability over the next 24 hours**.
- We also plan to exploit **metaheuristic methods** to solve the overloading prevention problem, that may help us to address the additions mentioned above.

- It would be interesting to analyze the intermediate states to find the **optimal order** of fuses' change.
- Also, applying a **dynamic soft curtailment** policy would be a desired feature for the smart grid users.
- Another interesting addition should be the appliance of a **fairness policy** to avoid curtailing the same users repetitively over time.
- We should also consider the future states of the grid and their inherent stochasticity, as the recovery response solution should **guarantee stability over the next 24 hours**.
- We also plan to exploit **metaheuristic methods** to solve the overloading prevention problem, that may help us to address the additions mentioned above.

- It would be interesting to analyze the intermediate states to find the **optimal order** of fuses' change.
- Also, applying a **dynamic soft curtailment** policy would be a desired feature for the smart grid users.
- Another interesting addition should be the appliance of a **fairness policy** to avoid curtailing the same users repetitively over time.
- We should also consider the future states of the grid and their inherent stochasticity, as the recovery response solution should **guarantee stability over the next 24 hours**.
- We also plan to exploit **metaheuristic methods** to solve the overloading prevention problem, that may help us to address the additions mentioned above.

Thank you for your attention!

Contact details

@ nikolaos.antoniadis@uni.lu
@niko_antoniadis

in www.linkedin.com/in/nikosantoniadis
S live:nantoniad

The 216 scenarios and these slides can be retrieved from
http://tiny.cc/ola2020_antoniadis



Linear transformation

$$P_j = \sum_{f=1}^{2n} A_{jf} w p_f, \forall j \in \{1, \dots, leq\} \quad (7)$$

$$z p_{jf} = \begin{cases} -w p_f, & A_{jf} = -1 \\ 0, & A_{jf} = 0 \\ w p_f, & A_{jf} = 1 \end{cases} \quad (9)$$

$$P_j = \sum_{f=1}^{2n} z p_{jf}, \forall j \in \{1, \dots, leq\} \quad (11)$$

$$-1 y_{jf1} + 0 y_{jf2} + 1 y_{jf3} = A_{jf}, \quad (13)$$

$$z p_{jf} = \begin{cases} -w p_f, & y_{jf1} = 1 \\ 0, & y_{jf2} = 1 \\ w p_f, & y_{jf3} = 1 \end{cases} \quad (15)$$

$$Q_j = \sum_{f=1}^{2n} A_{jf} w q_f, \forall j \in \{1, \dots, leq\} \quad (8)$$

$$z q_{jf} = \begin{cases} -w q_f, & A_{jf} = -1 \\ 0, & A_{jf} = 0 \\ w q_f, & A_{jf} = 1 \end{cases} \quad (10)$$

$$Q_j = \sum_{f=1}^{2n} z q_{jf}, \forall j \in \{1, \dots, leq\} \quad (12)$$

$$y_{jf1} + y_{jf2} + y_{jf3} = 1 \quad (14)$$

$$z q_{jf} = \begin{cases} -w q_f, & y_{jf1} = 1 \\ 0, & y_{jf2} = 1 \\ w q_f, & y_{jf3} = 1 \end{cases} \quad (16)$$

Linear transformation

$$P_j = \sum_{f=1}^{2n} A_{jf} wp_f, \forall j \in \{1, \dots, leq\} \quad (7) \quad Q_j = \sum_{f=1}^{2n} A_{jf} wq_f, \forall j \in \{1, \dots, leq\} \quad (8)$$

$$zp_{jf} = \begin{cases} -wp_f, & A_{jf} = -1 \\ 0, & A_{jf} = 0 \\ wp_f, & A_{jf} = 1 \end{cases} \quad (9) \quad zq_{jf} = \begin{cases} -wq_f, & A_{jf} = -1 \\ 0, & A_{jf} = 0 \\ wq_f, & A_{jf} = 1 \end{cases} \quad (10)$$

$$P_j = \sum_{f=1}^{2n} zp_{jf}, \forall j \in \{1, \dots, leq\} \quad (11) \quad Q_j = \sum_{f=1}^{2n} zq_{jf}, \forall j \in \{1, \dots, leq\} \quad (12)$$

$$-1y_{jf1} + 0y_{jf2} + 1y_{jf3} = A_{jf}, \quad (13) \quad y_{jf1} + y_{jf2} + y_{jf3} = 1 \quad (14)$$

$$zp_{jf} = \begin{cases} -wp_f, & y_{jf1} = 1 \\ 0, & y_{jf2} = 1 \\ wp_f, & y_{jf3} = 1 \end{cases} \quad (15) \quad zq_{jf} = \begin{cases} -wq_f, & y_{jf1} = 1 \\ 0, & y_{jf2} = 1 \\ wq_f, & y_{jf3} = 1 \end{cases} \quad (16)$$

Linear transformation

$$P_j = \sum_{f=1}^{2n} A_{jf} wp_f, \forall j \in \{1, \dots, leq\} \quad (7) \quad Q_j = \sum_{f=1}^{2n} A_{jf} wq_f, \forall j \in \{1, \dots, leq\} \quad (8)$$

$$zp_{jf} = \begin{cases} -wp_f, & A_{jf} = -1 \\ 0, & A_{jf} = 0 \\ wp_f, & A_{jf} = 1 \end{cases} \quad (9) \quad zq_{jf} = \begin{cases} -wq_f, & A_{jf} = -1 \\ 0, & A_{jf} = 0 \\ wq_f, & A_{jf} = 1 \end{cases} \quad (10)$$

$$P_j = \sum_{f=1}^{2n} zp_{jf}, \forall j \in \{1, \dots, leq\} \quad (11) \quad Q_j = \sum_{f=1}^{2n} zq_{jf}, \forall j \in \{1, \dots, leq\} \quad (12)$$

$$-1y_{jf1} + 0y_{jf2} + 1y_{jf3} = A_{jf}, \quad (13) \quad y_{jf1} + y_{jf2} + y_{jf3} = 1 \quad (14)$$

$$zp_{jf} = \begin{cases} -wp_f, & y_{jf1} = 1 \\ 0, & y_{jf2} = 1 \\ wp_f, & y_{jf3} = 1 \end{cases} \quad (15) \quad zq_{jf} = \begin{cases} -wq_f, & y_{jf1} = 1 \\ 0, & y_{jf2} = 1 \\ wq_f, & y_{jf3} = 1 \end{cases} \quad (16)$$

Linear transformation

$$P_j = \sum_{f=1}^{2n} A_{jf} wp_f, \forall j \in \{1, \dots, leq\} \quad (7)$$

$$zp_{jf} = \begin{cases} -wp_f, & A_{jf} = -1 \\ 0, & A_{jf} = 0 \\ wp_f, & A_{jf} = 1 \end{cases} \quad (9)$$

$$P_j = \sum_{f=1}^{2n} zp_{jf}, \forall j \in \{1, \dots, leq\} \quad (11)$$

$$-1y_{jf1} + 0y_{jf2} + 1y_{jf3} = A_{jf}, \quad (13)$$

$$zp_{jf} = \begin{cases} -wp_f, & y_{jf1} = 1 \\ 0, & y_{jf2} = 1 \\ wp_f, & y_{jf3} = 1 \end{cases} \quad (15)$$

$$Q_j = \sum_{f=1}^{2n} A_{jf} wq_f, \forall j \in \{1, \dots, leq\} \quad (8)$$

$$zq_{jf} = \begin{cases} -wq_f, & A_{jf} = -1 \\ 0, & A_{jf} = 0 \\ wq_f, & A_{jf} = 1 \end{cases} \quad (10)$$

$$Q_j = \sum_{f=1}^{2n} zq_{jf}, \forall j \in \{1, \dots, leq\} \quad (12)$$

$$y_{jf1} + y_{jf2} + y_{jf3} = 1 \quad (14)$$

$$zq_{jf} = \begin{cases} -wq_f, & y_{jf1} = 1 \\ 0, & y_{jf2} = 1 \\ wq_f, & y_{jf3} = 1 \end{cases} \quad (16)$$

Linear transformation

$$P_j = \sum_{f=1}^{2n} A_{jf} w p_f, \forall j \in \{1, \dots, leq\} \quad (7)$$

$$z p_{jf} = \begin{cases} -w p_f, & A_{jf} = -1 \\ 0, & A_{jf} = 0 \\ w p_f, & A_{jf} = 1 \end{cases} \quad (9)$$

$$P_j = \sum_{f=1}^{2n} z p_{jf}, \forall j \in \{1, \dots, leq\} \quad (11)$$

$$-1 y_{jf1} + 0 y_{jf2} + 1 y_{jf3} = A_{jf}, \quad (13)$$

$$z p_{jf} = \begin{cases} -w p_f, & y_{jf1} = 1 \\ 0, & y_{jf2} = 1 \\ w p_f, & y_{jf3} = 1 \end{cases} \quad (15)$$

$$Q_j = \sum_{f=1}^{2n} A_{jf} w q_f, \forall j \in \{1, \dots, leq\} \quad (8)$$

$$z q_{jf} = \begin{cases} -w q_f, & A_{jf} = -1 \\ 0, & A_{jf} = 0 \\ w q_f, & A_{jf} = 1 \end{cases} \quad (10)$$

$$Q_j = \sum_{f=1}^{2n} z q_{jf}, \forall j \in \{1, \dots, leq\} \quad (12)$$

$$y_{jf1} + y_{jf2} + y_{jf3} = 1 \quad (14)$$

$$z q_{jf} = \begin{cases} -w q_f, & y_{jf1} = 1 \\ 0, & y_{jf2} = 1 \\ w q_f, & y_{jf3} = 1 \end{cases} \quad (16)$$